







Première  
Vertikal  
days

# CTEZED 20.3 A+H

## MB Sprinter



 20 m\*
  8,8 m\*

 230 kg
  18 m

 1400x700x1100 mm
 **GVW min** 3,5 t

### DIMENSIONS

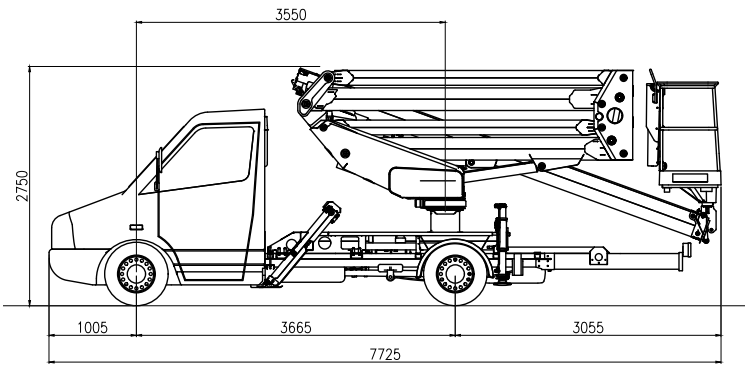

2250mm max width in running order

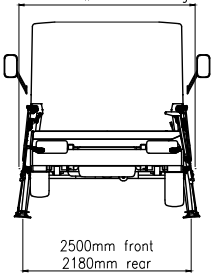

\* outreach and height max values and repeatability can change within  $\pm 3\%$  due to manufacturing variation and working condition.

### WORKING ENVELOPE

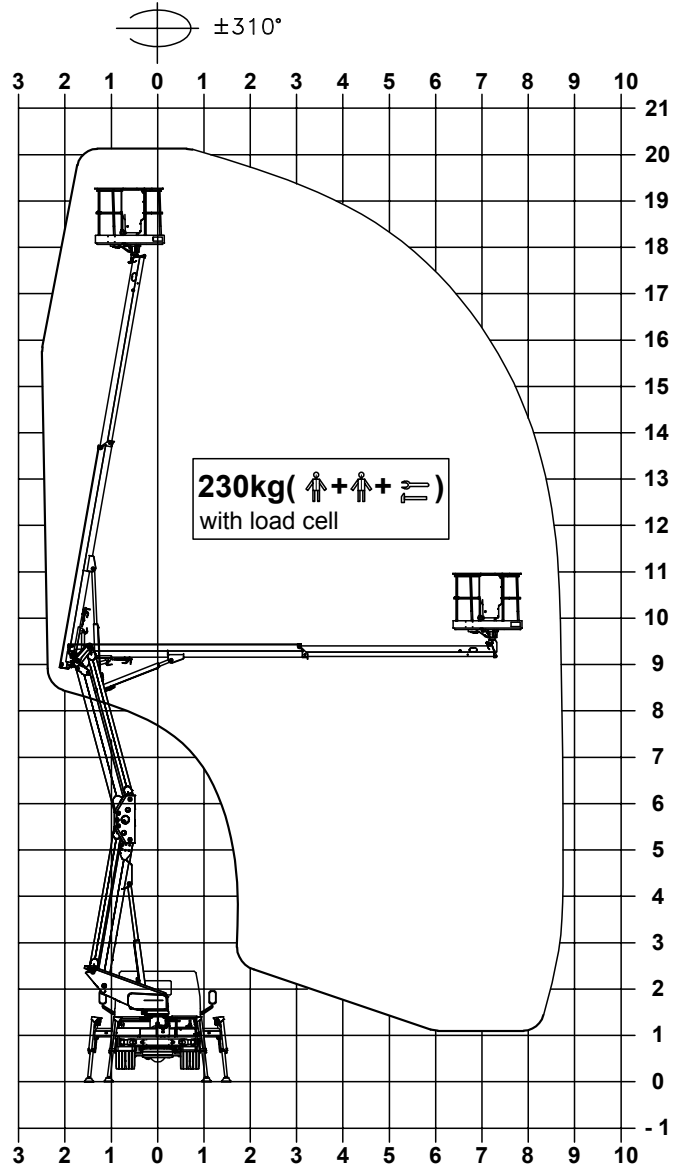

### A+H Stab System



### UP&OVER



### Max Capacity 230 kg



### Absolute verticality



**CTE S.p.A.**  
 Headquarter 7 Via Caproni - Rovereto (TN) IT, 38068  
 Factory 5 Loc. Terramatta - Rivoli Veronese (VR) IT, 37010  
 Warehouse 2 Via E. Fermi - Affi (VR) IT, 37010  
 CTE UK Ltd Enderby Leicestershire - UK  
 info@ctelift.com - [www.ctelift.com](http://www.ctelift.com)